

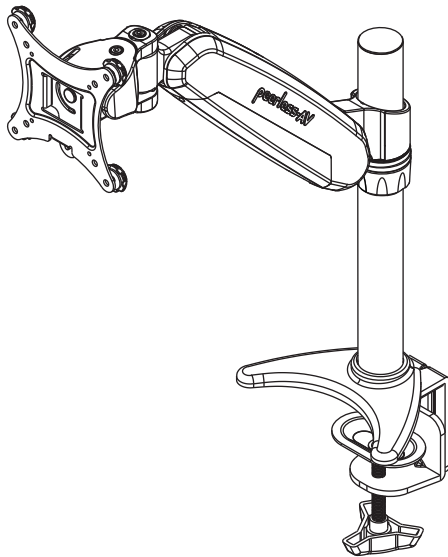

Installation and Assembly:  
**Desktop Mount with Desk Clamp and Grommet for 19" - 30"  
LCD Screens**

---

Models: LCT420A, LCT620A



**LCT420A**

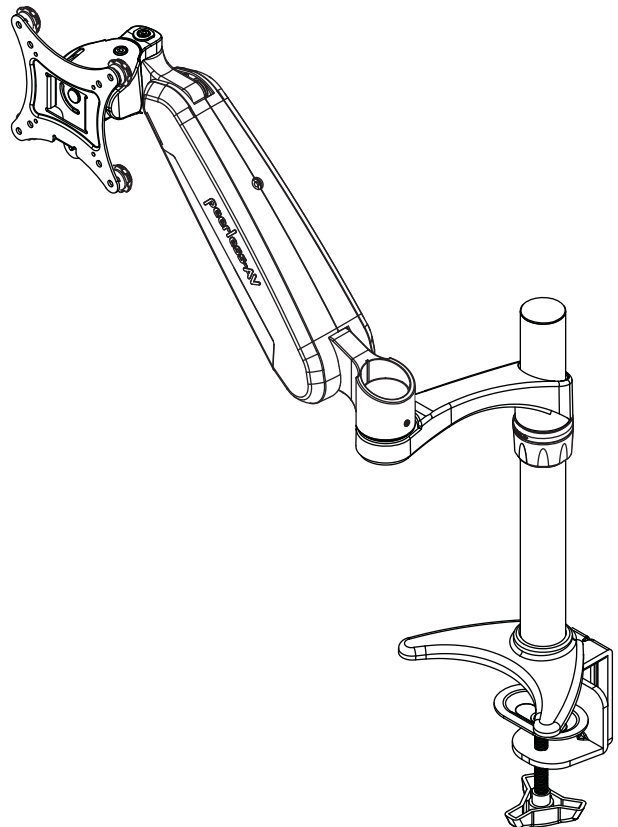

**LCT620A**

**Max Load Capacity: 15 lbs (6.8 kg)**

**NOTE:** Read entire instruction sheet before you start installation and assembly.

## **WARNING**

- Do not begin to install your Peerless product until you have read and understood the instructions and warnings contained in this Installation Sheet. If you have any questions regarding any of the instructions or warnings, please call Peerless customer care at 1-800-865-2112.
- This product should only be installed by someone of good mechanical aptitude, has experience with basic building construction, and fully understands these instructions.
- Make sure that the supporting surface will safely support the combined load of the equipment and all attached hardware and components.
- Never exceed the Maximum Load Capacity. See page 1.
- Always use an assistant or mechanical lifting equipment to safely lift and position equipment.
- Tighten screws firmly, but do not overtighten. Overtightening can damage the items, greatly reducing their holding power.
- This product is intended for indoor use only. Use of this product outdoors could lead to product failure and personal injury.

### **Tools Needed for Assembly**

- phillips screwdriver
- drill
- 3/8" (10 mm) drill bit

### **Table of Contents**

---

Parts List.....	3
Installation to Mounting Surface .....	4
Attaching Adapter Plate to Screen.....	5
Cable Management .....	6

Before you begin, make sure all parts shown are included with your product.

Description	LCT420A	LCT620A
	Qty	Qty
<b>A</b> column assembly	1	1
<b>B</b> single link arm assembly	1	-
double link arm assembly	-	1
<b>C</b> grommet assembly	1	1
<b>D</b> round rubber pads	2	2
<b>E</b> square rubber pads	2	2
<b>F</b> M4 x 12 mm phillips screw	4	4
<b>G</b> M4 x 25 mm phillips screw	4	4
<b>H</b> spacer	4	4
<b>I</b> 4 mm allen wrench	1	1
<b>J</b> 2.5 mm allen wrench	1	1
<b>K</b> cable clip	1	1
<b>L</b> cable tie	5	5
<b>M</b> adapter bracket	1	1

Parts may appear slightly different than illustrated.

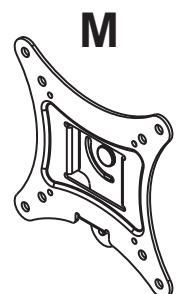
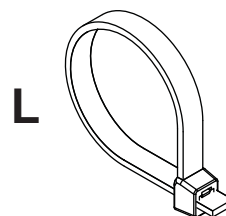
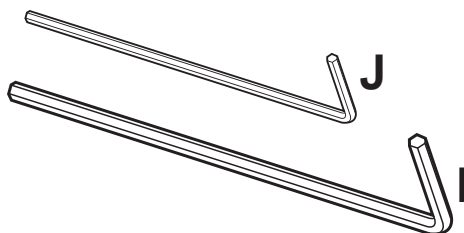
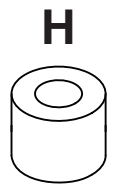
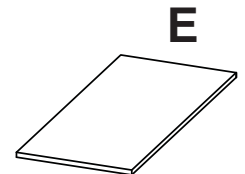
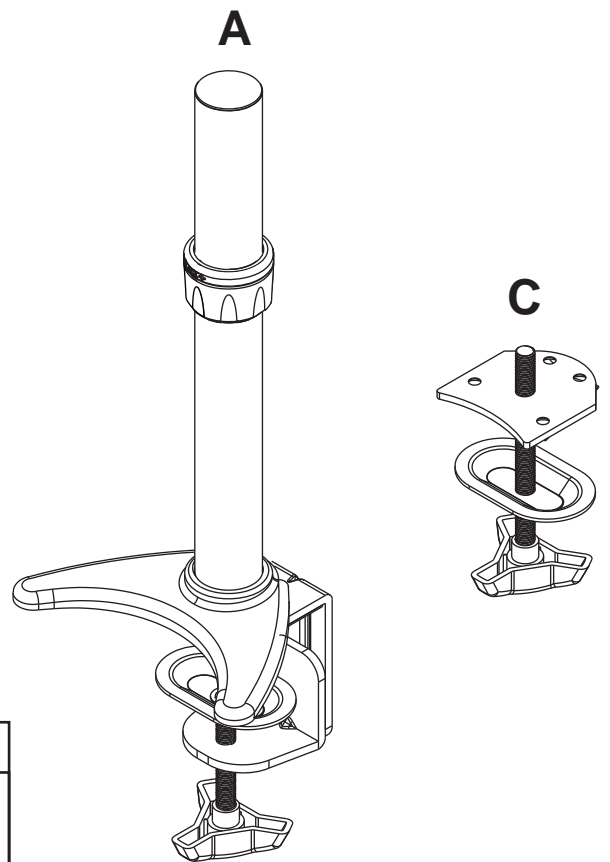
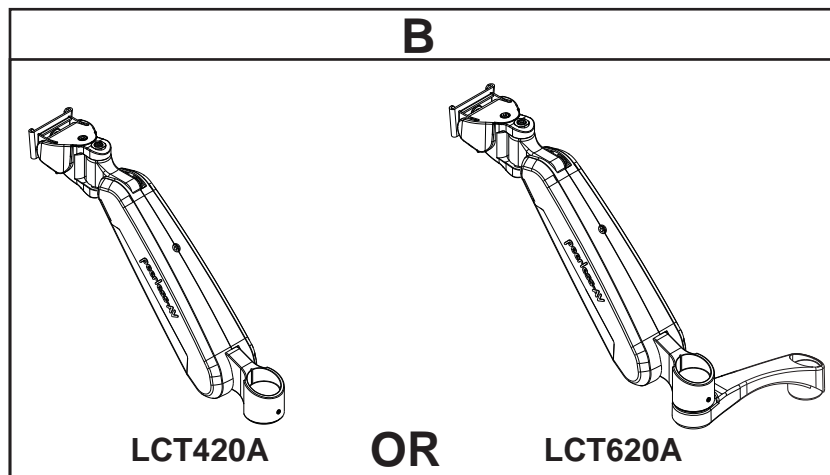

## Clamp Installation Method

- 1 Apply four rubber pads (**D**, **E**) to bottom of column assembly (**A**) as shown below. Attach column assembly (**A**) to mounting surface with a maximum thickness of 3".  
*Skip to step four.*

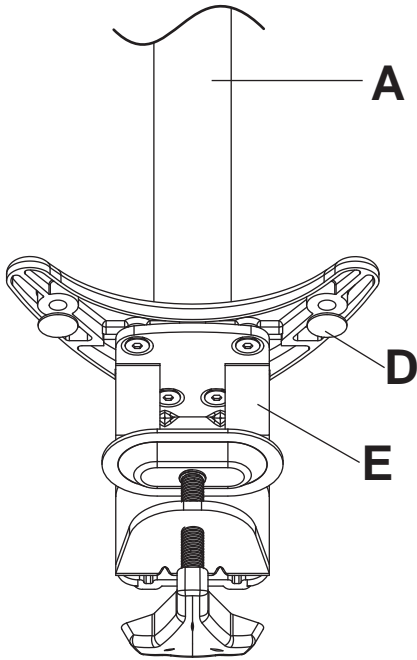

- 2 Apply four rubber pads (**D**, **E**) to bottom of column assembly (**A**) as shown below.

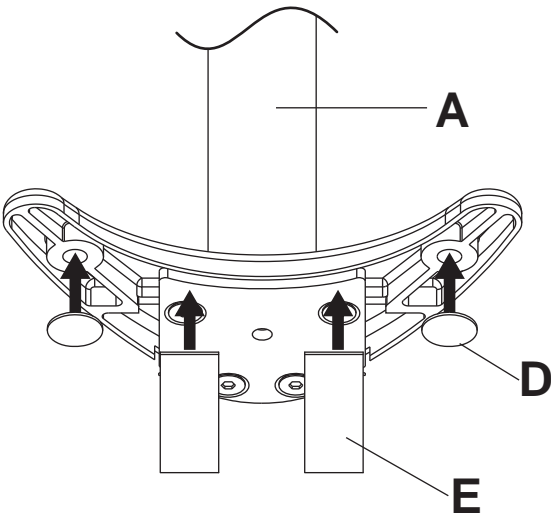

## Grommet Installation Method

- 1 Remove clamp assembly from column assembly (**A**) as shown in figure 1.1. Remove mounting plate from grommet assembly (**C**) and attach to column assembly (**A**) with four M6 x 8 mm screws using 4 mm allen wrench (**I**) as shown in figure 1.2.

fig. 1.1

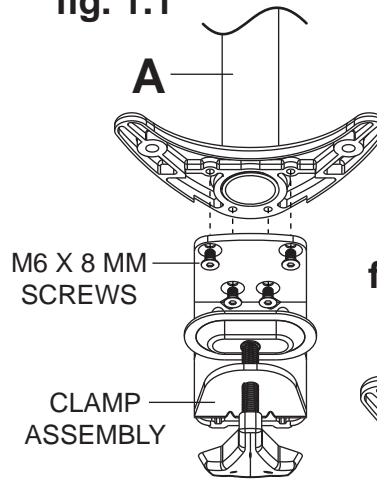
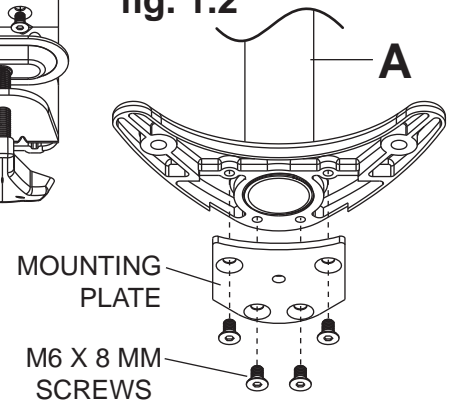
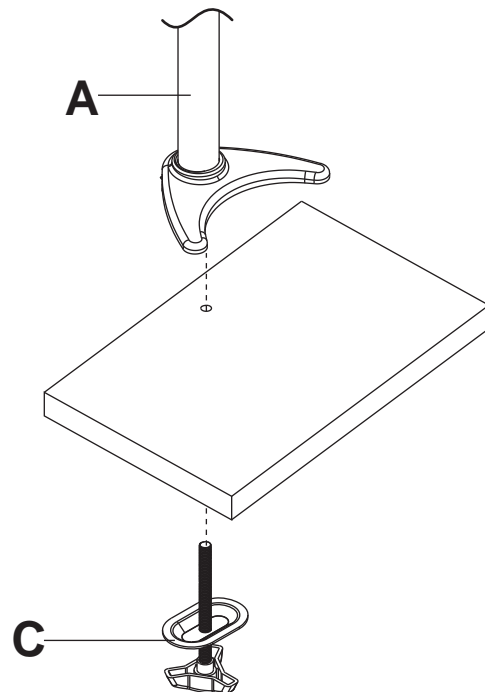

fig. 1.2



- 3 Drill a 3/8" (10mm) dia. hole through mounting surface with a maximum thickness of 3". Place column assembly (**A**) on mounting surface and secure using grommet assembly (**C**).



## Attaching Adapter Plate to Screen

### ⚠ WARNING

- Tighten screws so adapter plate is firmly attached. Do not tighten with excessive force. Overtightening can cause stress damage to screws, greatly reducing their holding power and possibly causing screw heads to become detached. Tighten to 40 in. • lb (4.5 N.M.) maximum torque.
- If screws don't get three complete turns into the screen inserts or if screws bottom out and arm is still not tightly secured, damage may occur to screen or product may fail.

**4** Remove knobs from adapter plate (**M**) as shown in figure 4.1.

**4-1** To prevent scratching the screen, set a cloth on a flat, level surface that will support the weight of the screen. Place screen face side down. If screen has knobs on the back, remove them to allow the adapter plate to be attached. Place adapter plate on back of screen.

Choose hole pattern as shown in detail 1.

**FOR DISPLAYS WITH FLAT BACKS:** Attach adapter plate to display using four knobs or 12mm screws (**F**) as shown in figure 4.2.

**FOR DISPLAYS WITH RECESSED BACKS:** Attach adapter plate to display using four 25mm screws (**G**) and four spacers (**H**) as shown in figure 4.3.

fig. 4.1

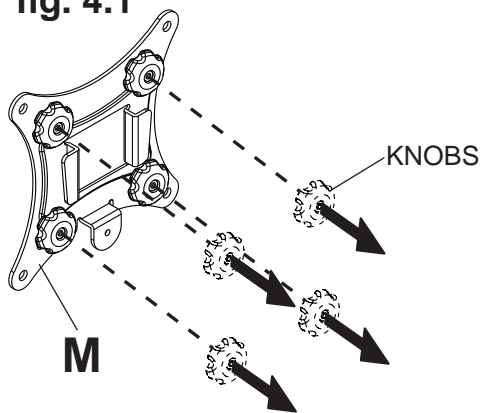
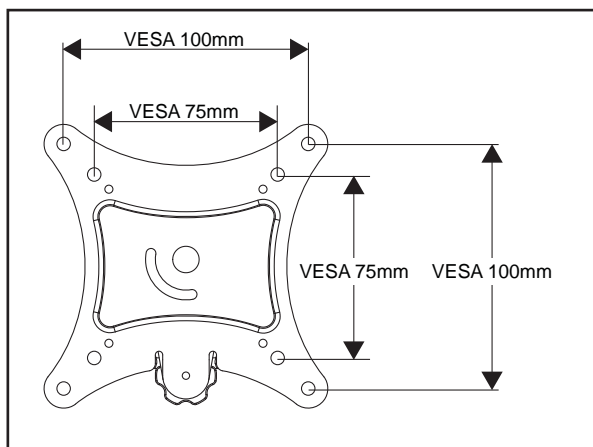
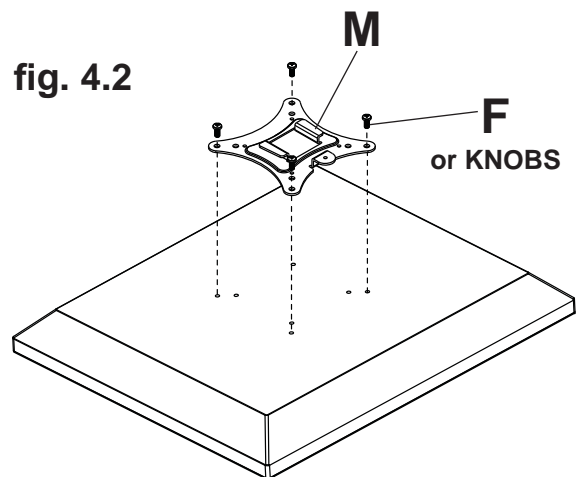
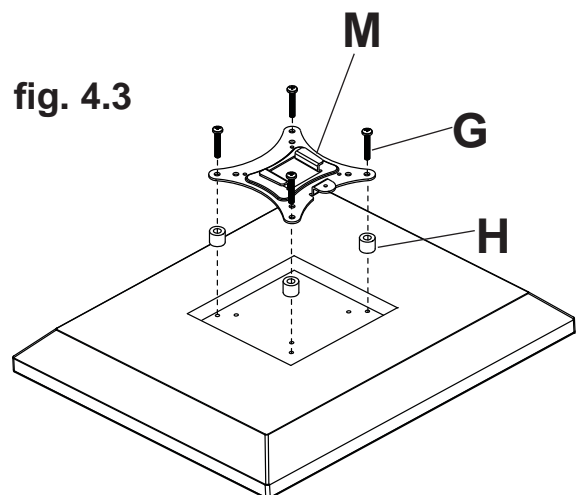

fig. 4.2



DETAIL 1

fig. 4.3



- Loosen and position lock collar to desired height and retighten lock collar as shown in figure 5.1.  
 Insert arm assembly (B) onto column assembly (A) and let it rest on lock collar as shown in figure 5.2.  
 Tighten set screw on rear of arm assembly (B) using 2.5 mm allen wrench (J) as shown in figure 5.3.

fig. 5.1

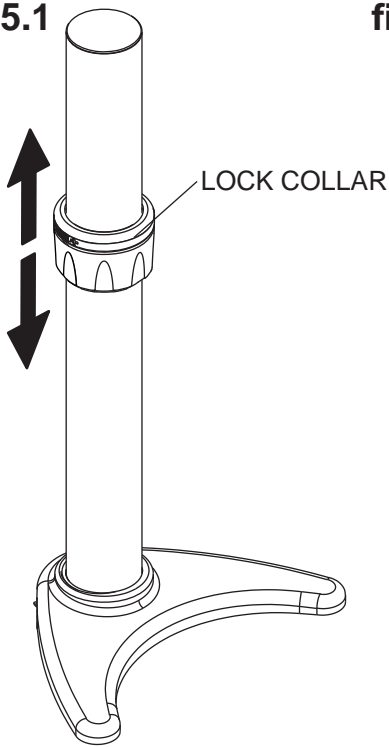

fig. 5.2

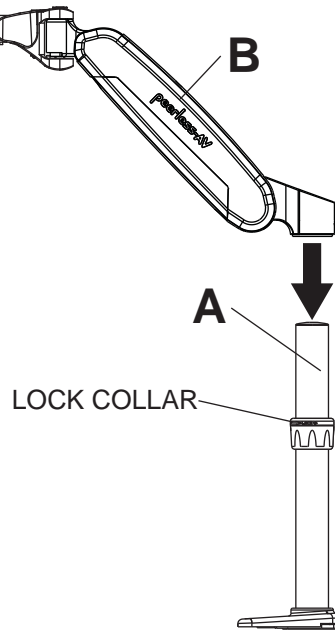
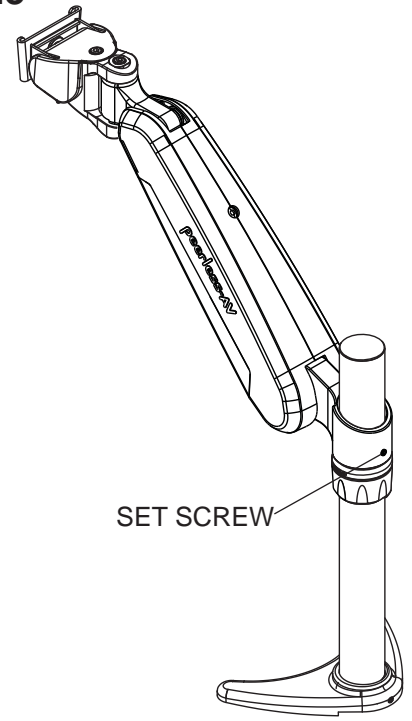
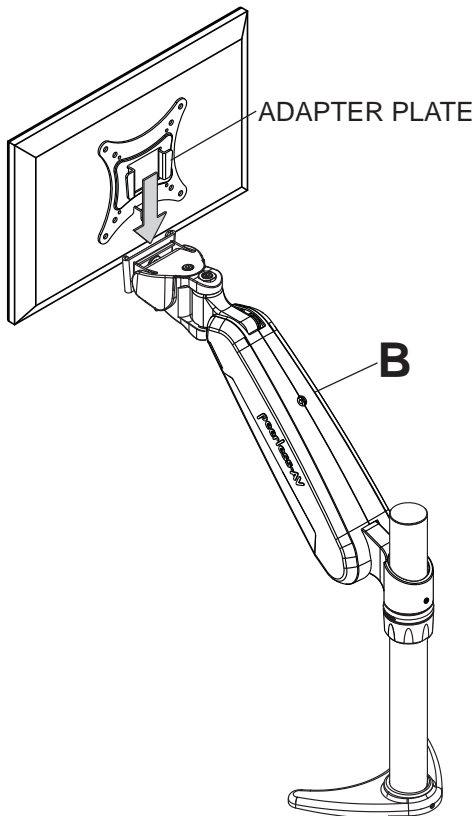

fig. 5.3



- Hook adapter plate onto arm assembly (B).



- Reinstall knob through back of arm assembly (B) and secure into back of adapter plate.

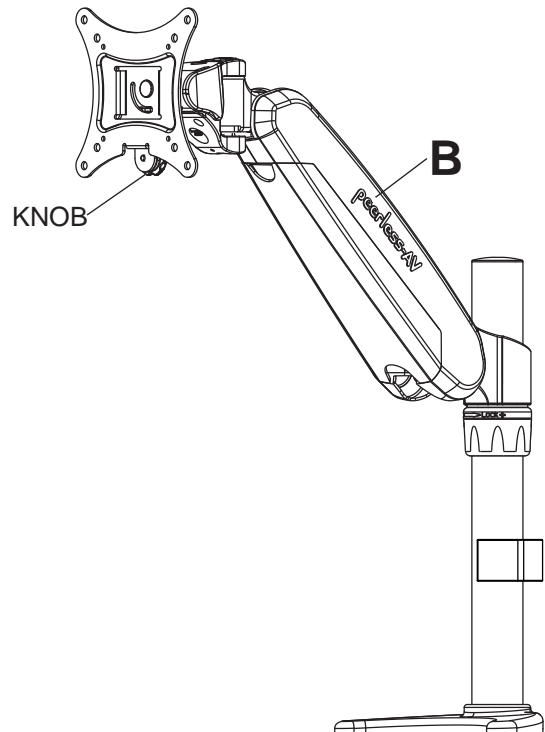

- 7** Cables may be routed using cavity in arm assembly (**B**) and cable clip (**K**). Remove the cable cover on arm assembly (**B**) by pressing firmly in the middle of the cable cover and then pulling the flanges of the cable cover. Route the cables in arm assembly (**B**) and then reinstall the cable cover.

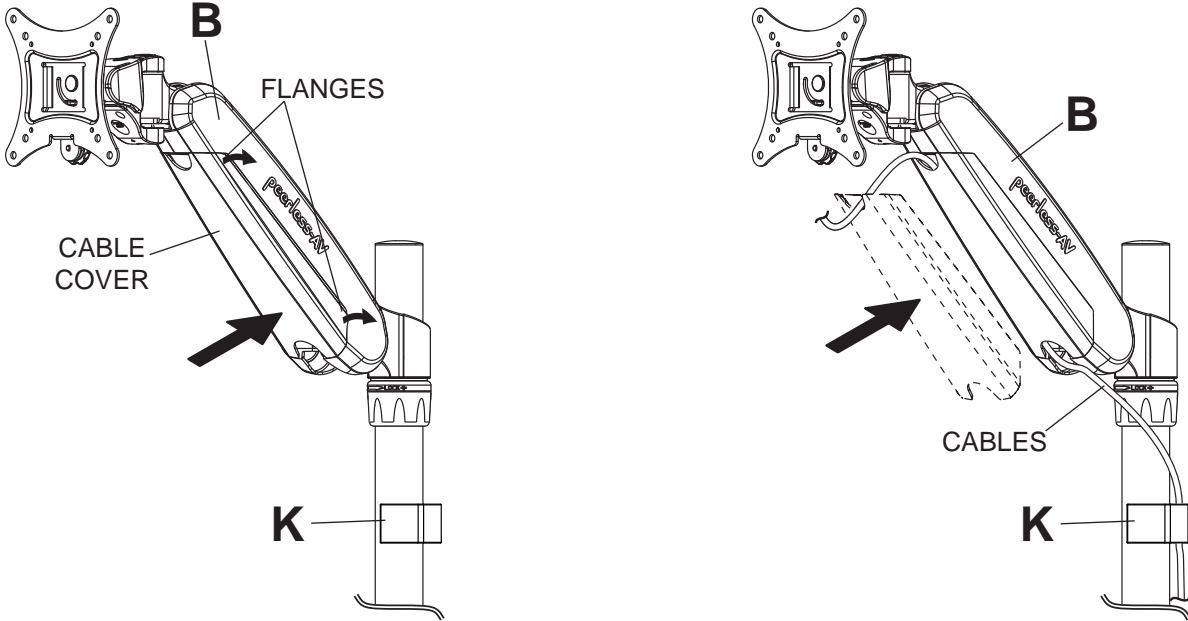

- 8** To lock down rotation, tighten set screw shown in detail 2.  
 To lock down tilt, tighten screw shown in detail 3.  
 To lock down swivel, tighten screw shown in detail 4.  
 To lock down height adjustment, tighten set screw shown in detail 5.

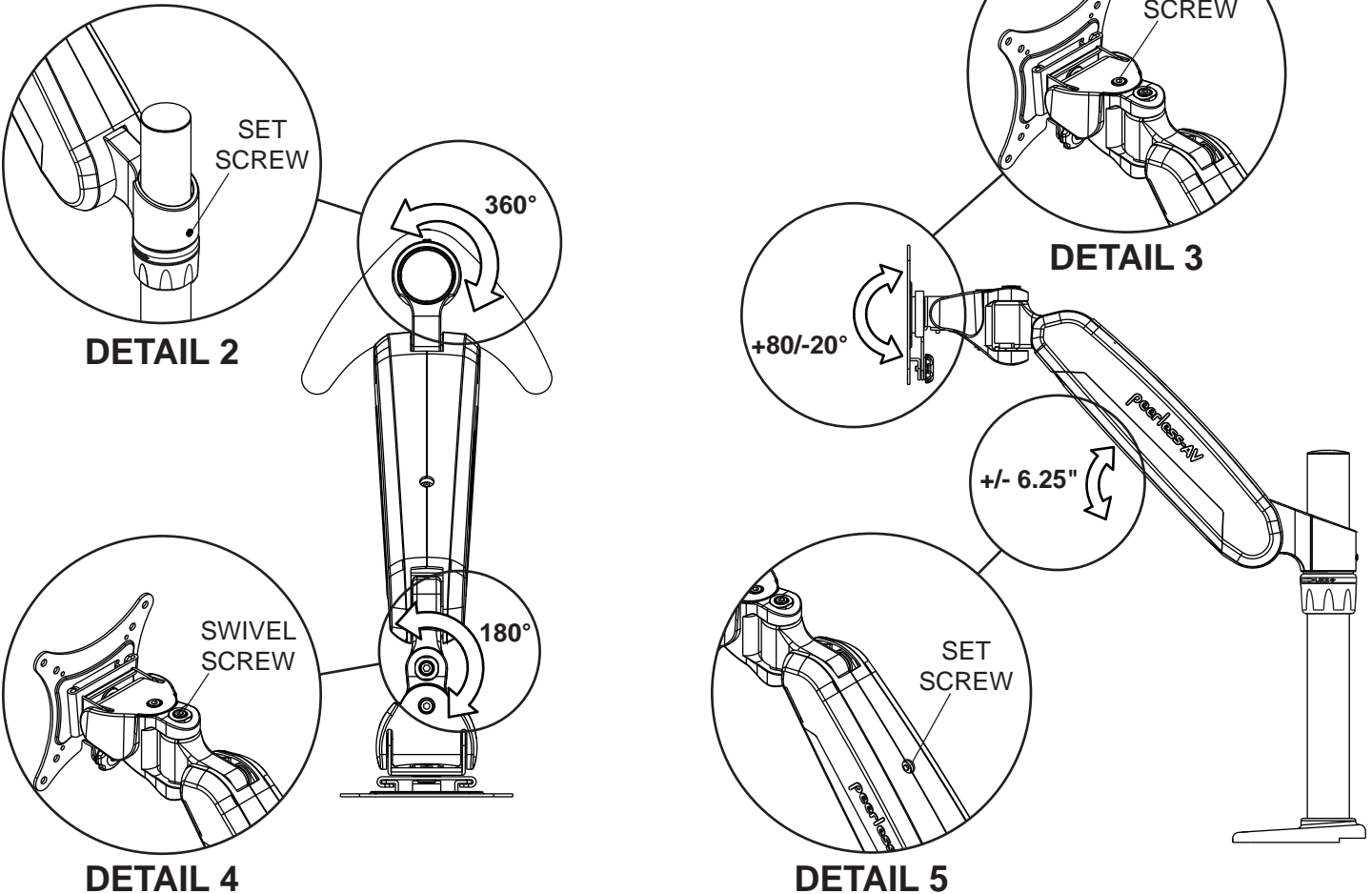

# LIMITED FIVE-YEAR WARRANTY

Peerless Industries, Inc. ("Peerless") warrants to original end-users of Peerless® products will be free from defects in material and workmanship, under normal use, for a period of five years from the date of purchase by the original end-user (but in no case longer than six years after the date of the product's manufacture). At its option, Peerless will repair or replace, or refund the purchase price of, any product which fails to conform with this warranty.

**In no event shall the duration of any implied warranty of merchantability or fitness for a particular purpose be longer than the period of the applicable express warranty set forth above.** Some states do not allow limitations on how long an implied warranty lasts, so the above limitation may not apply to you.

This warranty does not cover damage caused by (a) service or repairs by the customer or a person who is not authorized for such service or repairs by Peerless, (b) the failure to utilize proper packing when returning the product, (c) incorrect installation or the failure to follow Peerless' instructions or warnings when installing, using or storing the product, or (d) misuse or accident, in transit or otherwise, including in cases of third party actions and force majeure.

**In no event shall Peerless be liable for incidental or consequential damages or damages arising from the theft of any product, whether or not secured by a security device which may be included with the Peerless® product.** Some states do not allow the exclusion or limitation of incidental or consequential damages, so the above limitation or exclusion may not apply to you.

This warranty is in lieu of all other warranties, expressed or implied, and is the sole remedy with respect to product defects. No dealer, distributor, installer or other person is authorized to modify or extend this Limited Warranty or impose any obligation on Peerless in connection with the sale of any Peerless® product.

This warranty gives specific legal rights, and you may also have other rights which vary from state to state.

**peerless-AV**

[www.peerless-av.com](http://www.peerless-av.com)

© 2012 Peerless Industries, Inc.