



## FEATURES

- 1 CENTRIS™ TECHNOLOGY**  
**PATENTED FEATURE**  
 Provides smooth fingertip tilt in all directions using the screen's center of gravity. Screen angle stays set until you decide to readjust.
- 2 ADVANCED DISPLAY MOUNTING**  
 Teardrop hole pattern makes mounting the screen quick and easy.
- 3 STABLE BASE**  
 Heavy-duty, solid steel base and oversized pole for unmatched stability.
- 4 INDEPENDENT ADJUSTMENT**  
 Position each screen separately for ergonomic, horizontal alignment.
- 5 CABLE MANAGEMENT**  
 Conceal and protect cables using snap-on covers and cable clips.



## SPECIFICATIONS

Pole Height	14" (356 mm)
Max. Width Per Monitor	22.7" (577 mm)
Max. Height Per Monitor	26" (660 mm)
Tilt	±15°
Weight Capacity Per Monitor*	35 lbs (15.9 kg)
Colors	Black, Silver

\* Weight capacity given for KTP220. See [chiefmfg.com](http://chiefmfg.com) for more information on other product options.

## WHAT YOU NEED TO KNOW

### OTHER PRODUCT OPTIONS



**KTP225**  
Widescreen Dual Table Stand



**KTP230**  
Dual Vertical Table Stand



**KTP320 / KTP325**  
Triple Horizontal Table Stand (standard/widescreen)



**KTP440 / KTP445**  
Quad Monitor Table Stand (standard/widescreen)



**KTP445**  
Widescreen Quad Monitor Table Stand

## TECHNICAL DRAWINGS

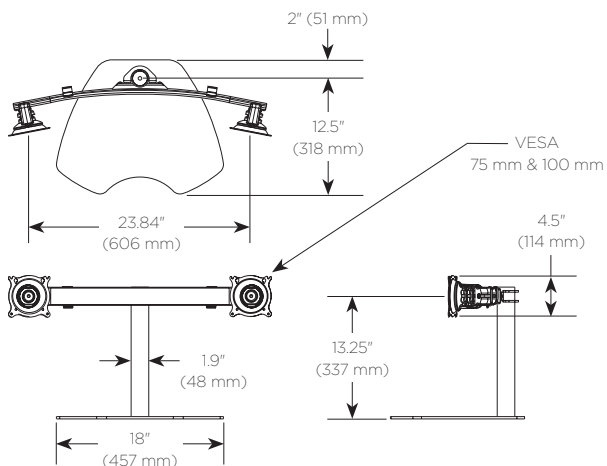

## RECOMMENDED ACCESSORIES



**KSA1024** ■ Centris Quick-Connect Interface

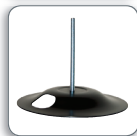

**KTA1000** ■ Grommet Bolt Through Accessory



**KTA1001** ■ Array Connector

For a complete list of monitor mount accessories see page 121.