

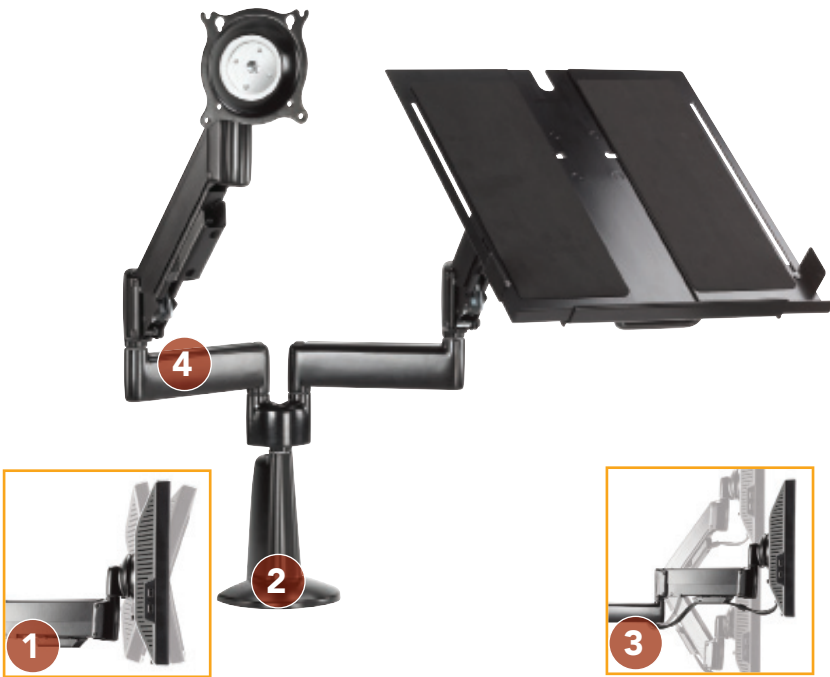

LAPTOP MONITOR MOUNTS KGL220™ DUAL HORIZONTAL DESK MOUNT



FEATURES

- 1 CENTRIS® TECHNOLOGY**
PATENTED FEATURE
Provides smooth fingertip tilt in all directions using the screen's center of gravity. Screen angle stays set until you decide to readjust.
- 2 EASY 3-STEP INSTALLATION**
Ships fully assembled, clamp option can be installed from top of desk, grommet bolt through hardware included.
- 3 FINGERTIP HEIGHT ADJUSTMENT**
Adjust viewing height up to 13.25" (337 mm). Optimize height adjustment for any display with customizable tension.
- 4 ULTIMATE FLEXIBILITY**
Maximum range of motion from low profile to full extension.

WHAT YOU NEED TO KNOW

INSTALLING THE MONITOR MOUNT

The mounting surface thickness must not exceed 3.2" (81 mm), and the grommet hole size must be between 0.38 - 3" (10 - 76 mm).

OTHER PRODUCT OPTIONS



KGL110
Height-Adjustable Laptop Desk Mount

SPECIFICATIONS

Depth (closed)	2.19" (56 mm)
(Monitor, Laptop)	15" (381 mm)
Max. Extension	20" (508 mm)
(Monitor, Laptop)	31.5" (800 mm)
Height Adjustment	13.25" (337 mm)
Tilt	±15°
Weight Capacity	5-25 lbs (2.3 - 11.4 kg)
(Monitor, Laptop)	15 lbs (6.9 kg)
Max. Laptop Width	16.75" (425 mm)
Colors	Black, Silver

RECOMMENDED ACCESSORIES



KSA1003 ■ Extension Arm
– Maximum of 3 arms
– Weight capacity is reduced to 30 lbs (13.6 kg)



KSA1008 ■ Extended Desk Clamp Bracket
– Compatible with 2.5" - 5" (64-127 mm) thick surfaces



KSA1012 ■ Extended Reach Desk Clamp Bracket

TECHNICAL DRAWINGS

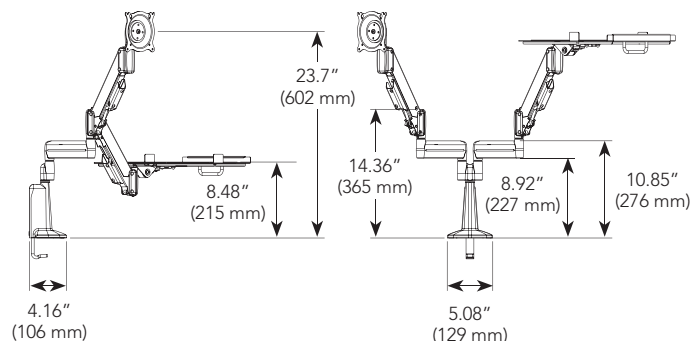

For a complete list of monitor mount accessories see page 111.